

### TRIPLEX CABLE AWG No 4/0

#### 1 Phase Cores

• Material		→	Aluminium 1350 (H19)
• Conductor Size		→	# 4/0 AWG
• Nominal Area		→	107.2 mm <sup>2</sup>
• Number of Aluminium Wires		→	19
• Shape of Conductor		→	Stranded Compressed
• Compressed Dia	Nominal	→	13 mm
• Rated Strength	Min	→	17 kN
• Lay Direction		→	Z Right Hand
• Phase Core Lay Factor - 6 Layer	Min	→	8
	Max	→	16
• Phase Core Lay Factor - 12 Layer	Min	→	8
	Max	→	16
• Calculated D.C Resistance at 20°C	Max	→	0.282 Ω/km
• Insulation Material		→	XLPE
• Insulation Colour		→	Black
• Insulation Thickness	Avg	→	2 mm
• Insulation Thickness	Min	→	1.7 mm
• Core Identification	Phase 1	→	Plain
	Phase 2	→	1 Ridge

#### 2 Neutral Core

• Material		→	Aluminium Alloy - 6201
• Conductor Size		→	# 4/0 AWG
• Nominal Area		→	107.2 mm <sup>2</sup>
• Construction		→	7/4.42 mm
• Tensile Strength of Single Wire		→	315 Mpa
• Shape of Conductor		→	Circular Stranded
• Rated Strength	Min	→	32.5 kN
• Lay Direction		→	Z Right Hand
• Neutral Core Lay Factor	Min	→	10
	Max	→	16
• Calculated D.C Resistance at 20°C	Max	→	0.312 Ω/km
• Core Identification		→	Bare

#### 3 Complete Cable

• Maximum Lay Pitch	→	1200 mm
• Lay Direction	→	Z Right Hand
• Marking To Be Engraved	→	Manufacturers Name at 1m Interval

Reference Standards: ASTM B231, ASTM 399, ASTM 230 Customers Specification, NFC 33-209, ASTM B 901

**R.A Arunajith Perera**  
**Electrical Engineer**  
**Technical Services Department**  
**ACL**

Date of issue: 23.05.2014

Issue No: 01

Page: 1 of 1

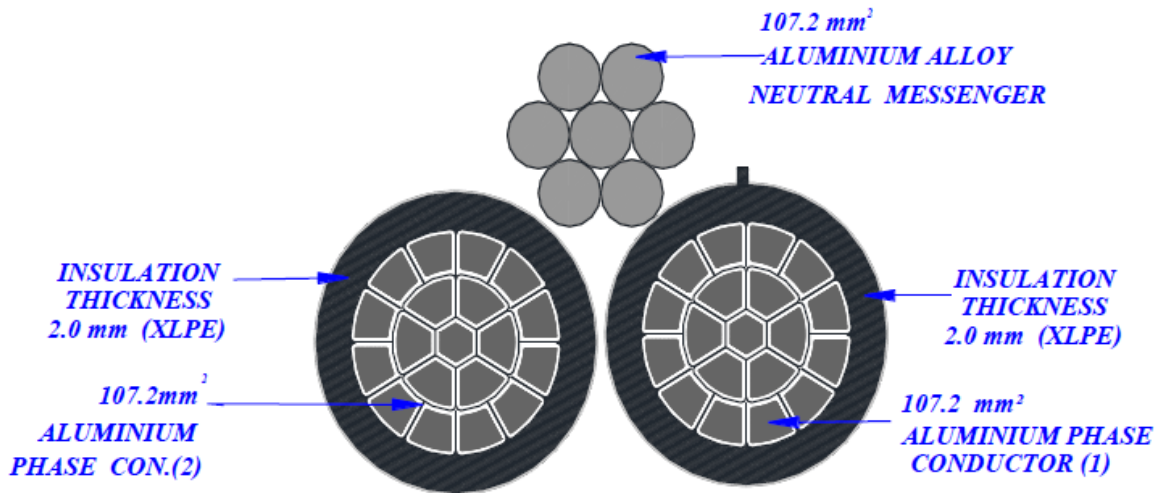

R.A Arunajith Perera  
 Electrical Engineer  
 Technical Services Department  
 ACL

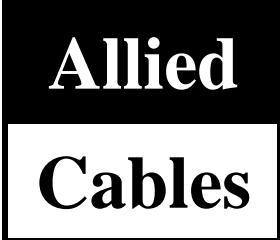

<b>Allied Cables Ltd</b>		Allied Works, Liverpool Road, Warrington, Cheshire WA5 1AP	
<b>2 x 107.2mm<sup>2</sup> AL/XLPE + 107.2mm<sup>2</sup> AL Alloy - Triplex</b>			
<b>Item Code: T - 3273</b>			
Checked: Eng.Ex		Approved: EE (TSD)	
Date:	08-Nov-16	Scale:	not to scale